

TOP VIEW

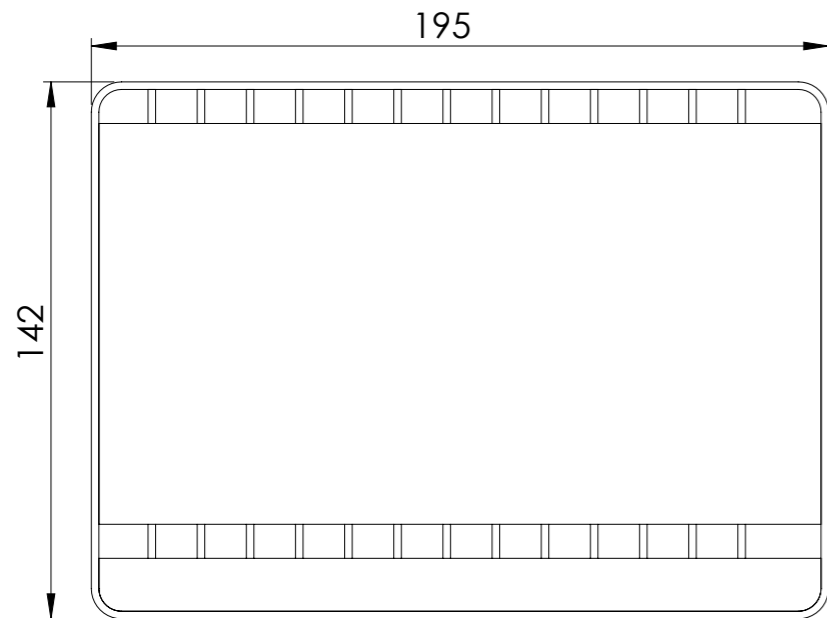

FRONT VIEW

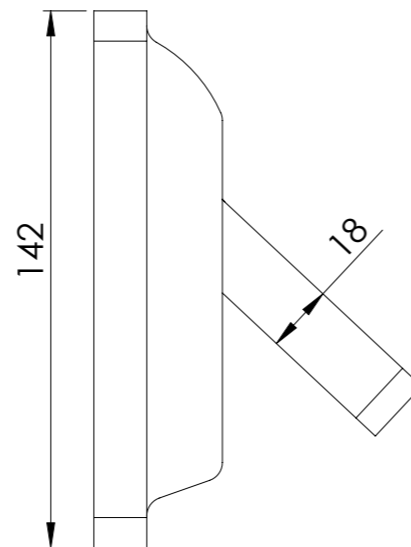

SIDE VIEW



ISOMETRIC VIEW

REV. Control		PROPRIETARY AND CONTAINED THE INFORMATION CONTAINED IN THIS DRAWING IS THE SOLE PROPERTY OF SGS WEATHER, ANY REPRODUCTION IN PART OR AS A WHOLE WITHOUT THE WRITTEN PERMISSION OF SGS FRANGIBLE TOWER Pvt. Ltd. IS PROHIBITED.
REV.	DATE	
1	15/07/2020	

UNLESS OTHERWISE SPECIFIED:		NAME	DATE	 SGS Frangible Tower Pvt. Ltd. Plot No. 36, Udyog Vihar Phase - IV Gurugram Haryana - 122015 INDIA
DIMENSIONS ARE IN MILLIMETERS		DRAWN	ALOK SHUKLA 15/07/2020	
TOLERANCES:		CHK'D	VIPIN GANDHI 15/07/2020	
FRACTIONAL ±		ENG APPR.		
ANGULAR: MACH ±		MFG APPR.		
TWO PLACE DECIMAL ±		Q.A		
THREE PLACE DECIMAL ±		SCALE :	1:2	
INTERPRET GEOMETRIC TOLE TANCING		COMMENTS:		
MATERIAL Aluminium		DWG NO. SGS-CUST-PL-036		
FINISH: N.A		SIZE A3	DRG. NAME Led Light, Wind Sock	REV 1
DO NOT SCALE DRAWING		WEIGHT : 950gms.		SHEET 1 OF 1