

TOP VIEW

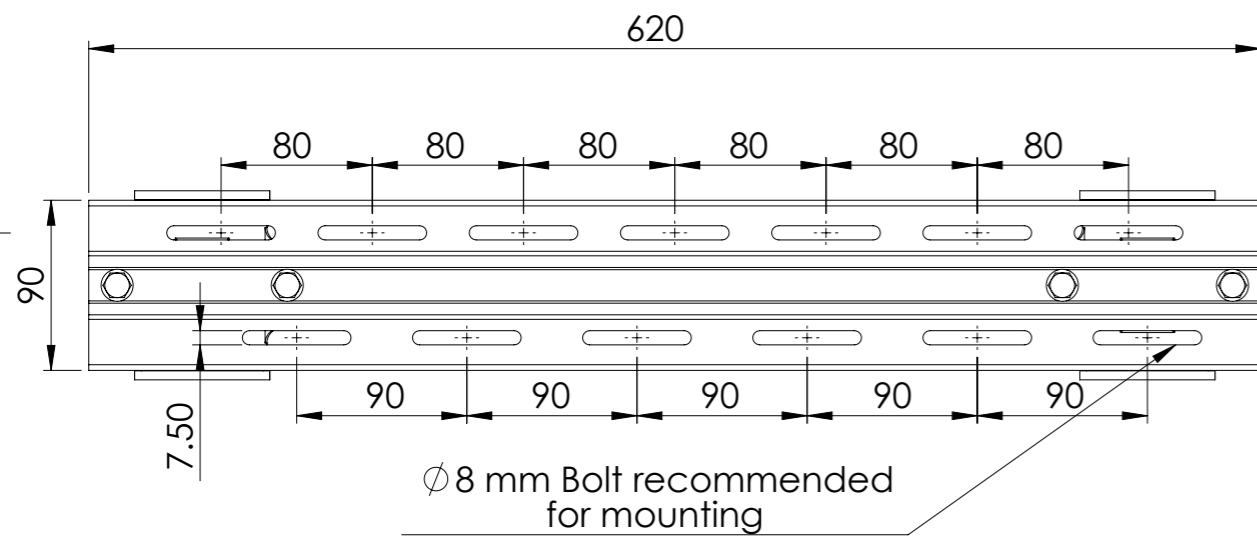

FRONT VIEW

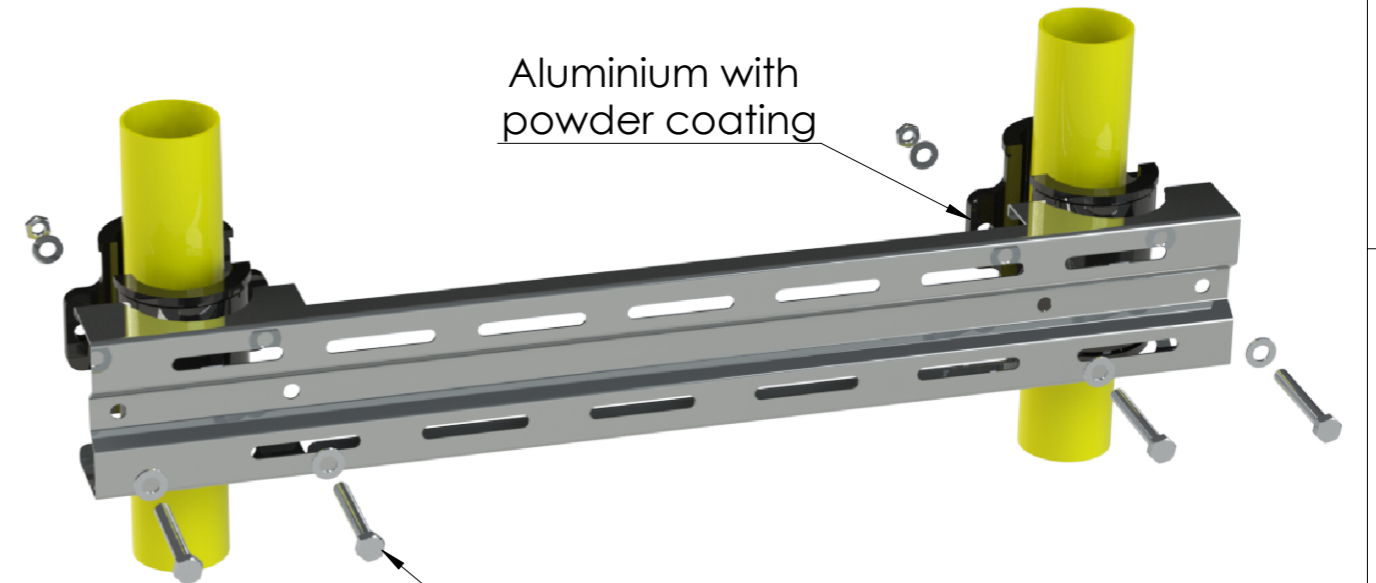

EXPLODED VIEW

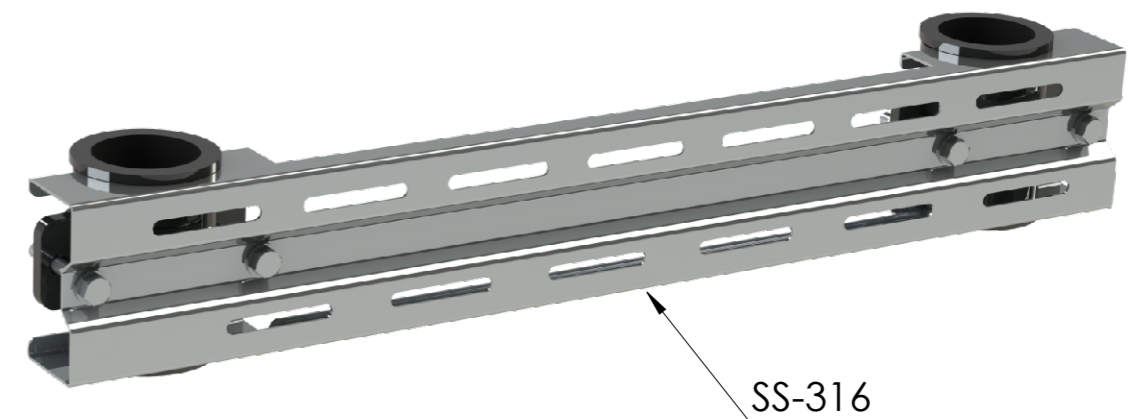

ISOMETRIC VIEW

S.NO	DESCRIPTION	QTY.
1	Front SS plate	1
2	Mounting Bolts, nuts, washer	4
3	Aluminium Gripping clamp	2 set

REV. Control		PROPRIETARY AND CONTAINED THE INFORMATION CONTAINED IN THIS DRAWING IS THE SOLE PROPERTY OF SGS WEATHER, ANY REPRODUCTION IN PART OR AS A WHOLE WITHOUT THE WRITTEN PERMISSION OF SGS FRANGIBLE TOWERS Pvt. Ltd. IS PROHIBITED.
REV.	DATE	
1	14/07/2020	

UNLESS OTHERWISE SPECIFIED:		NAME	DATE
DIMENSIONS ARE IN MILLIMETERS		DRAWN	ALOK SHUKLA 22-10-19
TOLERANCES:		CHK'D	VIPIN GANDHI 22-10-19
FRACTIONAL ±		ENG APPR.	
ANGULAR: MACH ±		MFG APPR.	
TOW PLACE DECIMAL ±		Q.A	
THREE PLACE DECIMAL ±			
INTERPRET GEOMETRIC TOLETANCING		SCALE :	1:5
MATERIAL	SS 316	COMMENTS: Optional Accessories	
FINISH:	MAT		
DO NOT SCALE DRAWING			

DWG NO.	SGS-CUST-JB-030
SIZE	DRG. NAME
A3	JUNCTION BOX MOUNTING
WEIGHT :	1.6 K.G
SHEET	1 OF 1



SGS Frangible Tower Pvt. Ltd.
Plot No. 36, Udyog Vihar
Phase - IV Gurugram
Haryana - 122015 INDIA