

TOP VIEW

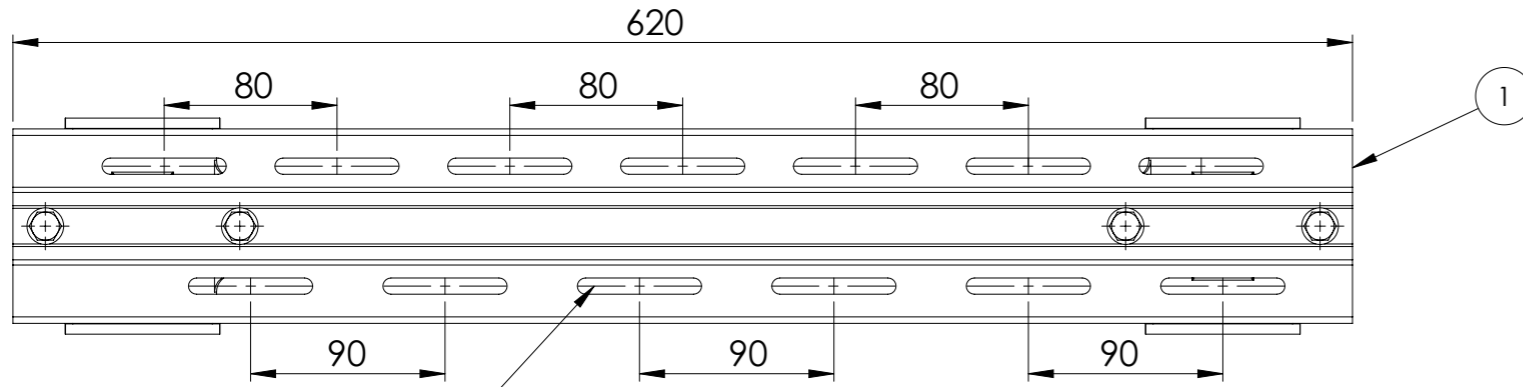

FRONT VIEW

Ø 8 Bolt recommended for mounting

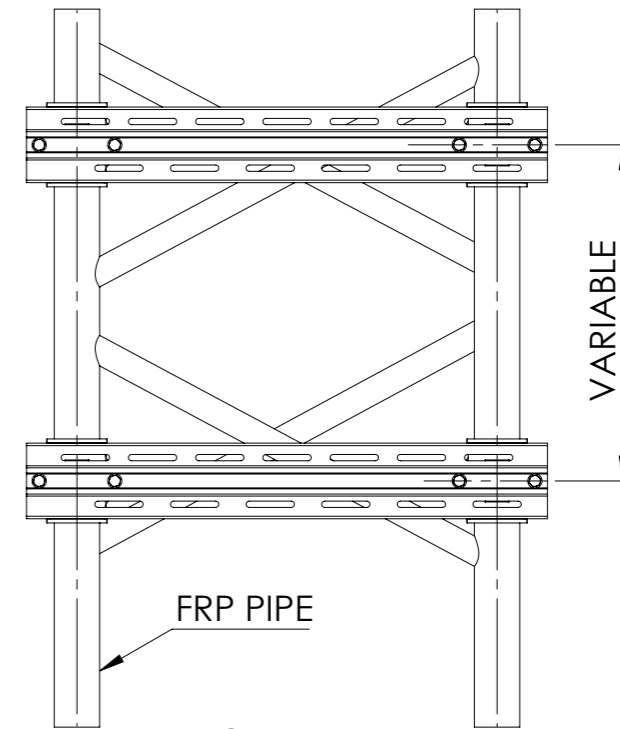

FRONT VIEW

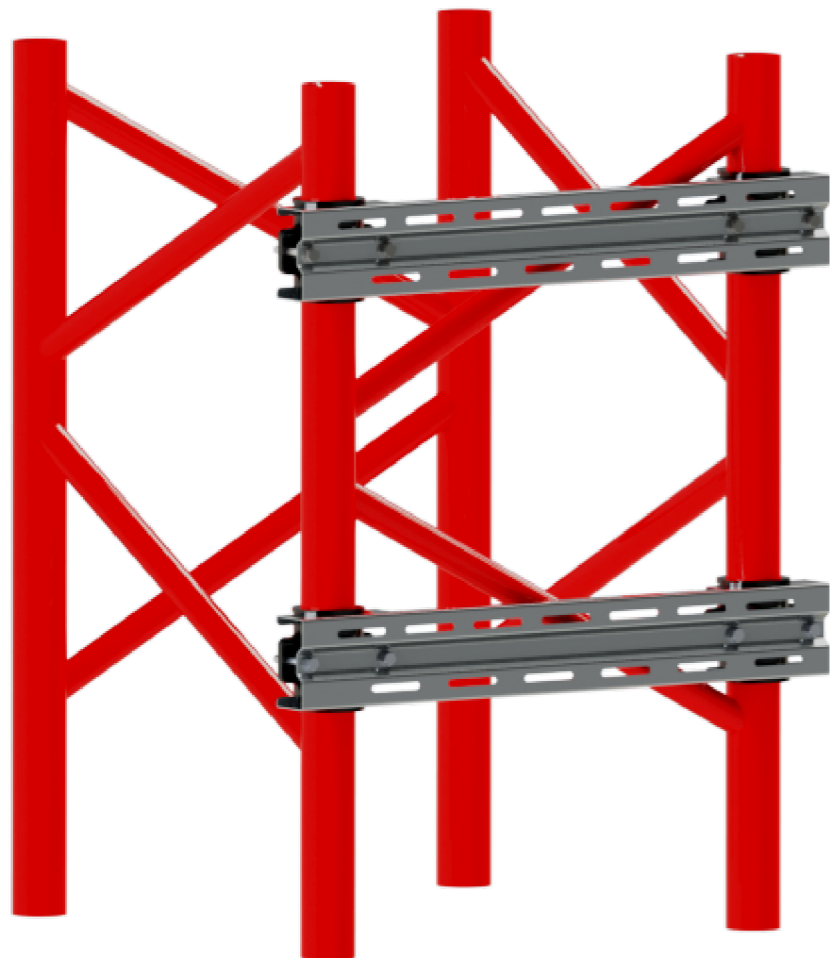

ISOMETRIC VIEW

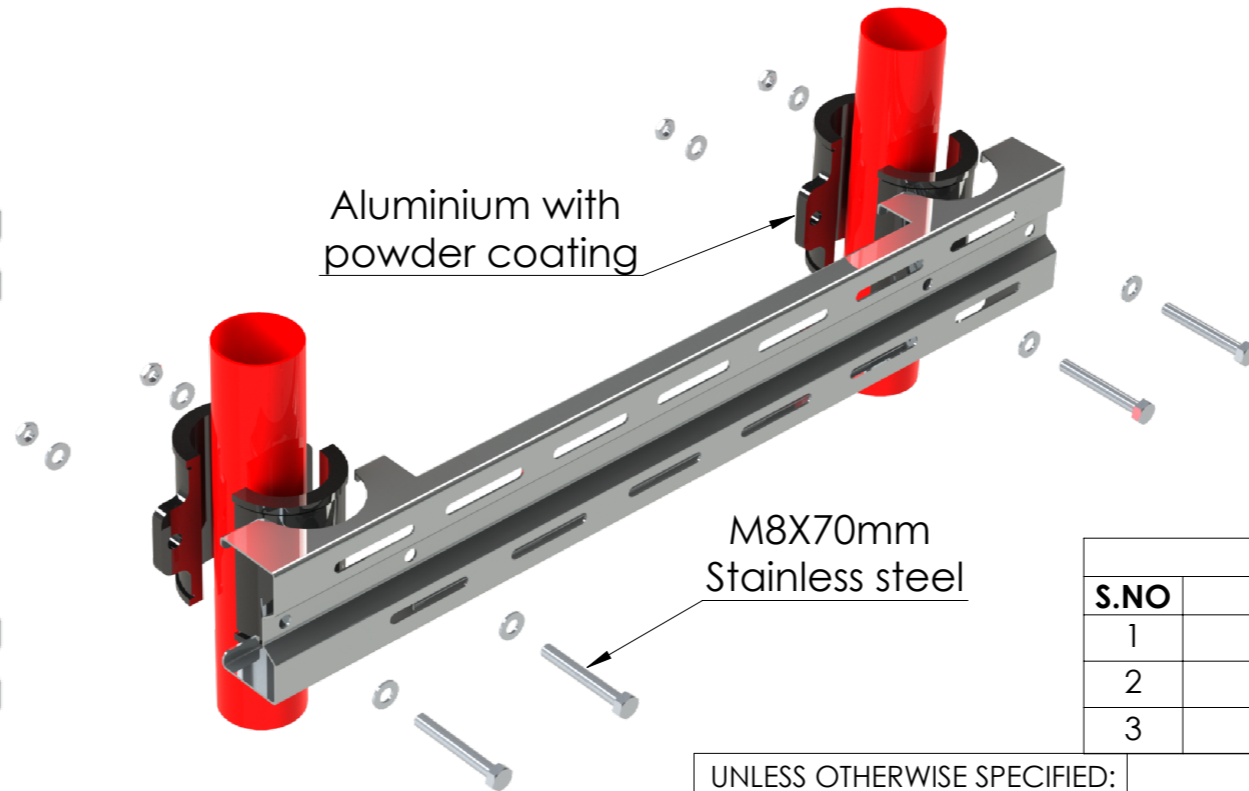

BILL OF MATERIAL		
S.NO	DESCRIPTION	QTY.
1	Front SS plate	2
2	Mounting Bolts, nuts, washer	8
3	Aluminium Gripping clamp	4 set

REV.	DATE
1	14/07/2020

PROPRIETARY AND CONTAINED
 THE INFORMATION CONTAINED IN THIS DRAWING IS THE SOLE PROPERTY OF SGS WEATHER, ANY REPRODUCTION IN PART OR AS A WHOLE WITHOUT THE WRITTEN PERMISSION OF SGS FRANGIBLE TOWER Pvt. Ltd. IS PROHIBITED.

UNLESS OTHERWISE SPECIFIED:
DIMENSIONS ARE IN MILLIMETERS
 TOLERANCES:
 FRACTIONAL ±
 ANGULAR: MACH ±
 TOW PLACE DECIMAL ±
 THREE PLACE DECIMAL ±
 INTERPRET GEOMETRIC TOLENTANCING
 MATERIAL SS 316
 FINISH: MAT
 DO NOT SCALE DRAWING

	NAME	DATE
DRAWN	ALOK SHUKLA	14/07/2020
CHK'D	VIPIN GANDHI	14/07/2020
ENG APPR.		
MFG APPR.		
Q.A		

SCALE: 1:10
 COMMENTS: Optional Accessories



SGS Frangible Tower Pvt. Ltd.
 Plot No. 36, Udyog Vihar
 Phase - IV Gurugram
 Haryana - 122015 INDIA

DWG NO. SGS-CUST-EM-029
 SIZE **A3** DRG. NAME **ENCLOSURE MOUNTING** REV **1**
 WEIGHT: 4.3 K.G SHEET 1 OF 1