

**TOP VIEW**

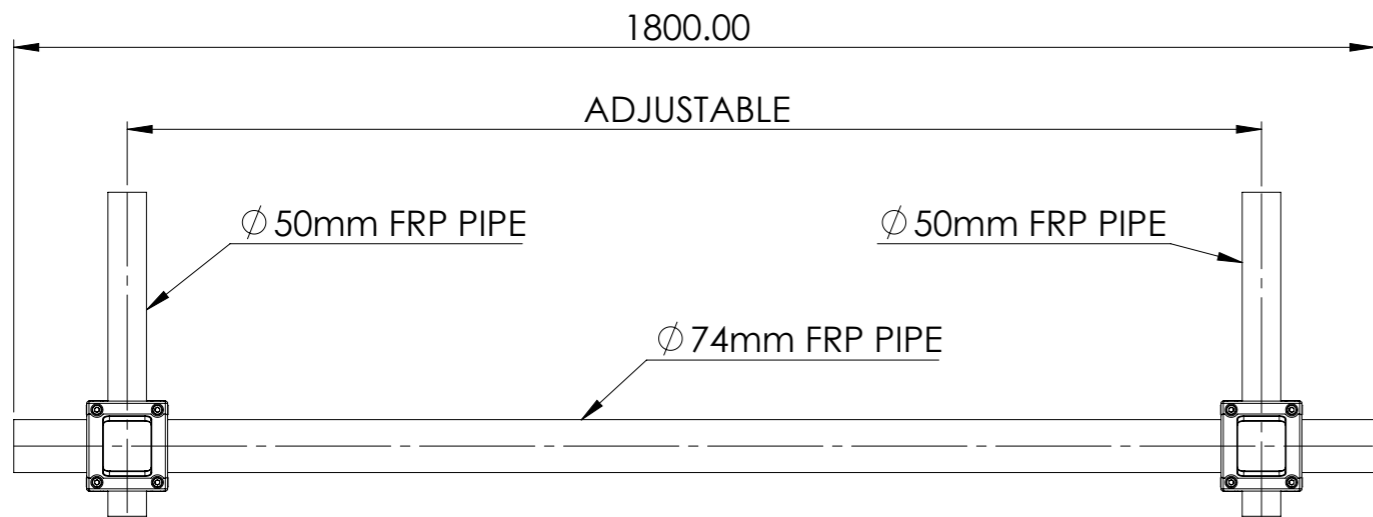

**FRONT VIEW**



**ISOMETRIC VIEW**

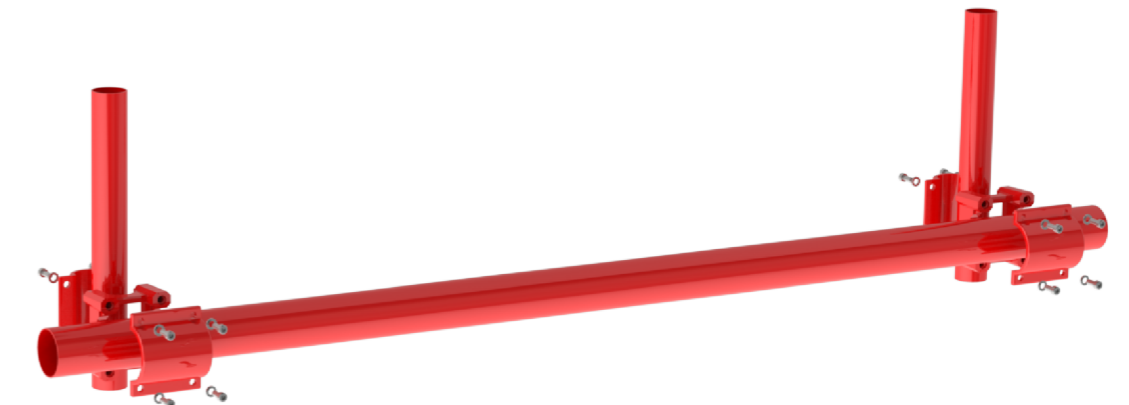

**EXPLODED VIEW**

REV. Control		PROPRIETARY AND CONTAINED THE INFORMATION CONTAINED IN THIS DRAWING IS THE SOLE PROPERTY OF SGS WEATHER, ANY REPRODUCTION IN PART OR AS A WHOLE WITHOUT THE WRITTEN PERMISSION OF SGS FRANGIBLE TOWERS Pvt. Ltd. IS PROHIBITED.
REV.	DATE	
1	23-01-2020	

UNLESS OTHERWISE SPECIFIED:		NAME	DATE
<b>DIMENSIONS ARE IN MILLIMETERS</b>		DRAWN	ALOK SHUKLA 23-01-2020
TOLERANCES:		CHK'D	VIPIN GANDHI 23-01-2020
FRACTIONAL ±		ENG APPR.	
ANGULAR: MACH ±		MFG APPR.	
TOW PLACE DECIMAL ±		Q.A	
THREE PLACE DECIMAL ±			
INTERPRET GEOMETRIC TOLERANCING		SCALE :	1:10
MATERIAL COMPOSITE MATERIAL		COMMENTS:	
FINISH: PU PAINT			
DO NOT SCALE DRAWING			

**SGS Frangible Tower Pvt. Ltd.**  
Plot No. 36, Udyog Vihar  
Phase - IV Gurugram  
Haryana - 122015 INDIA

DWG NO. SGS-CUST-CA180-032	
SIZE A3	DRG. NAME <b>CROSS ARM CA-180</b>
WEIGHT : 1.6 K.G	REV <b>1</b>
SHEET 1 OF 1	